

START OF PARKING STRUCTURE:

THURSDAY JULY 8TH, 2021

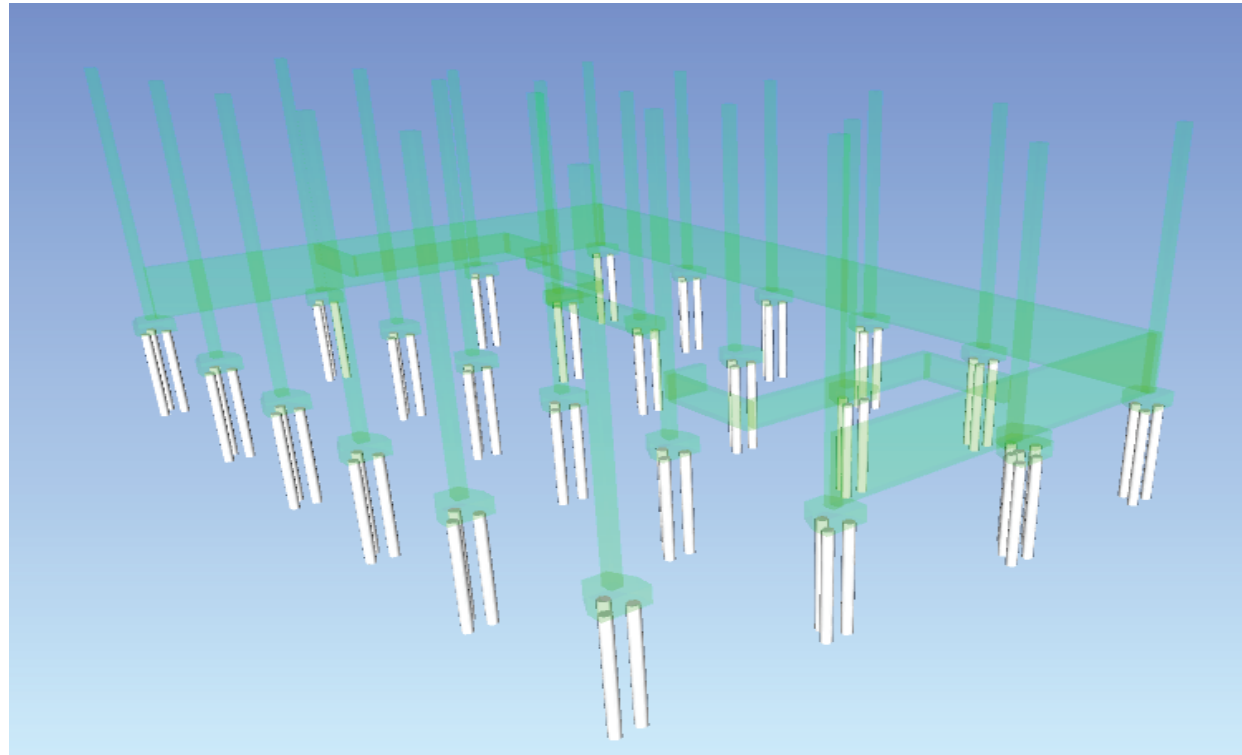

PILE CAPS COMPLETION:

MONDAY JULY 26TH, 2021

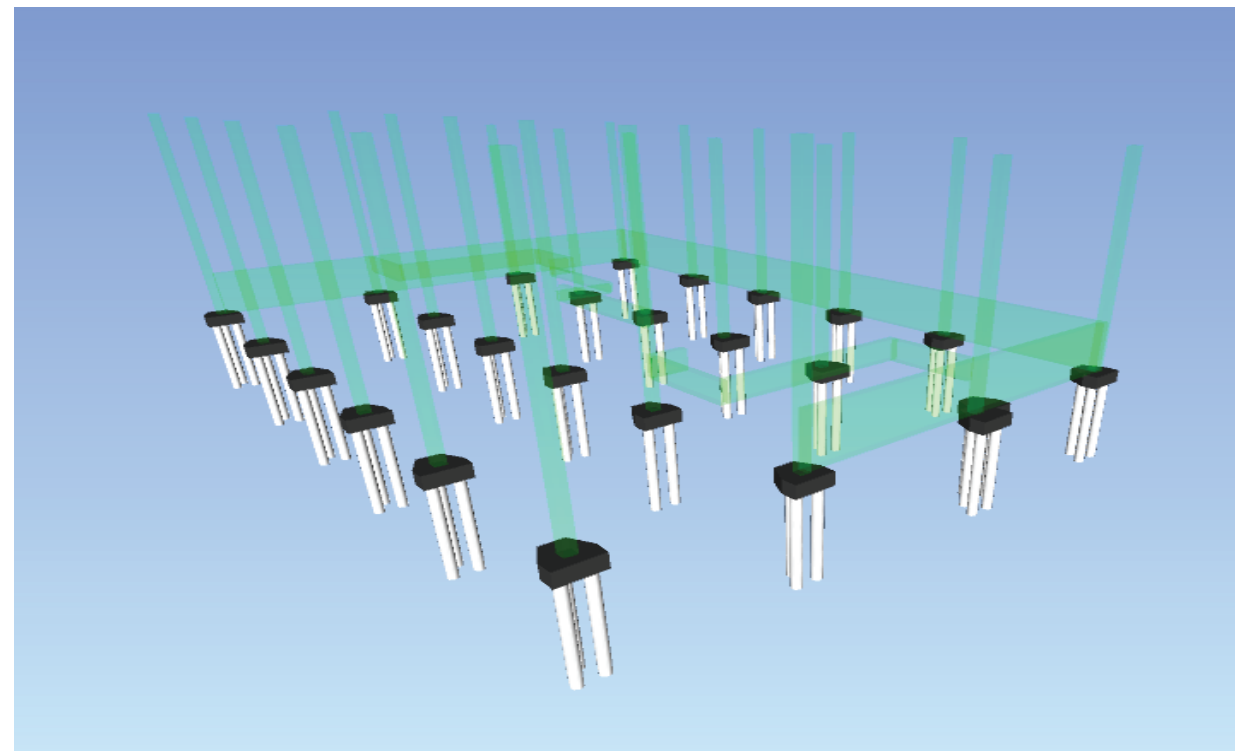

CMU ELVATOR/STAIR SHAFT WALLS:

TUESDAY 9/28/2021 - WED 11/10/2021

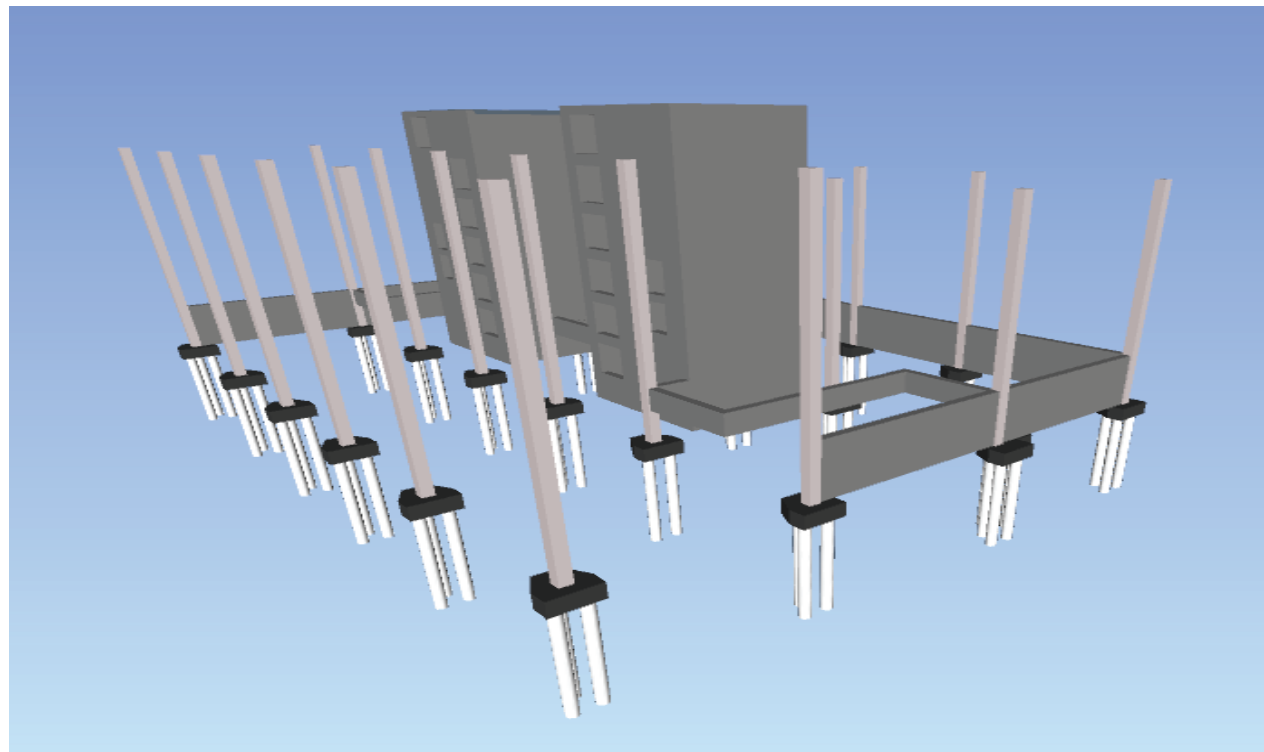

COLLABORATIVE
STUDIO 3B
GROUP 16

MEMBERS	INSTRUCTORS
CJ CHILDERS	ALEXIS GREGORY
CONNER GRIFFIN	MOHSEN GARSHASBY
LUKE MURRAY	BRIAR JONES
NOAH HEFLIN	HANS HERRMANN

PROJECT NUMBER
ASSIGNMENT 5.0

DATE
04/16/2021

DRAWN BY:
NOAH HEFLIN

DESIGN
DEVELOPMENT
5.0

C111

LEVEL ONE OF PARKING GARAGE COMPLETION:

MARCH 7, 2022

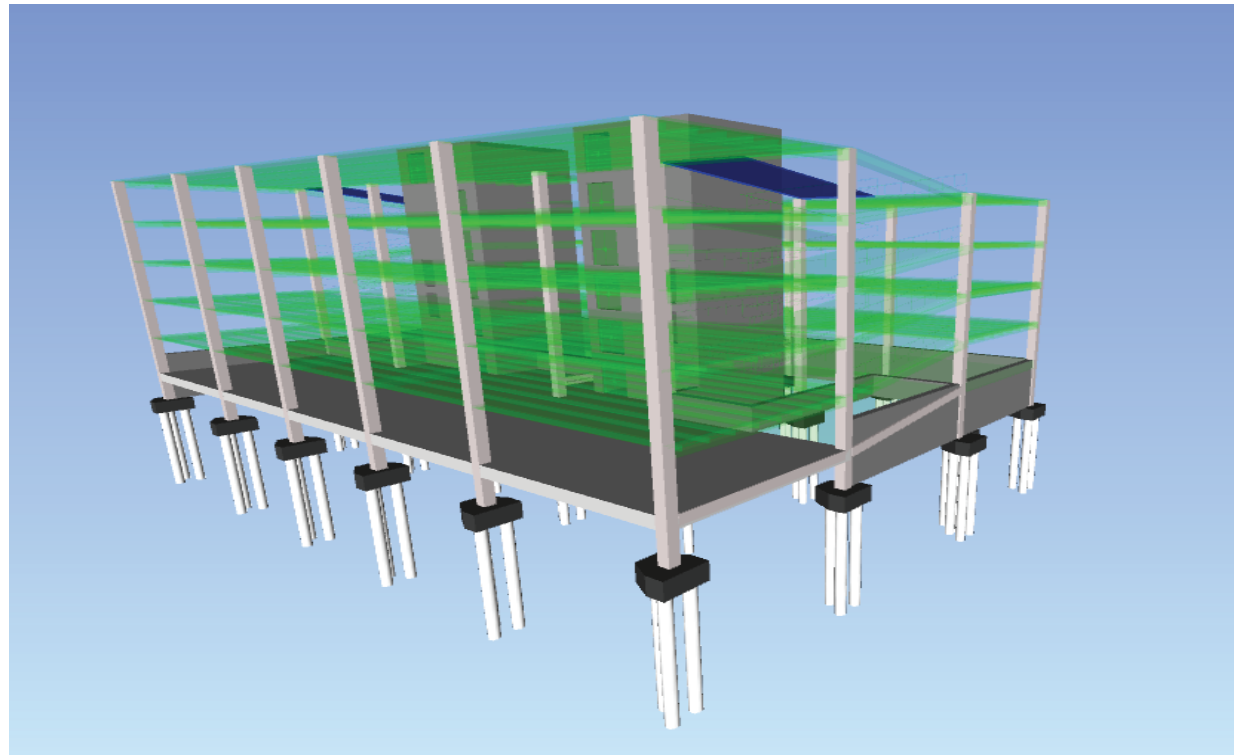

PRECAST PANELS TO ARRIVE ON SITE:

FEB 22, 2023

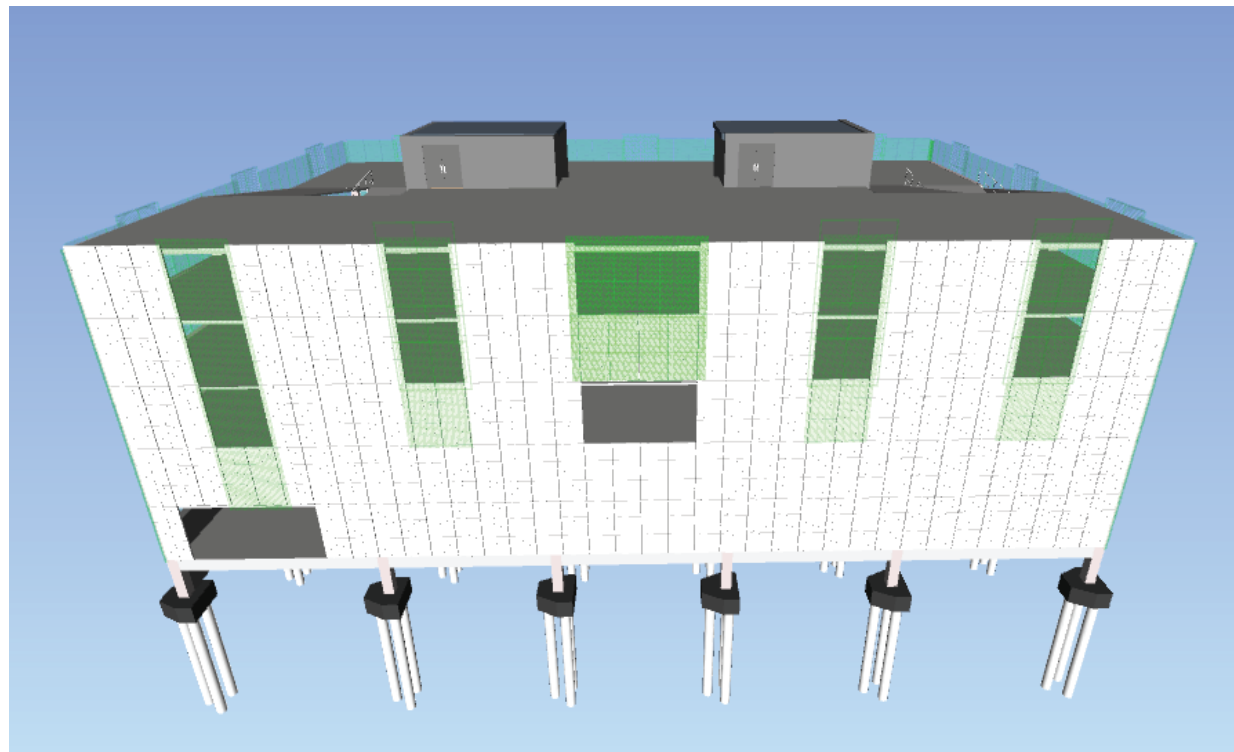

PARKING GARAGE TOPPING OUT:

FEB 22, 2023

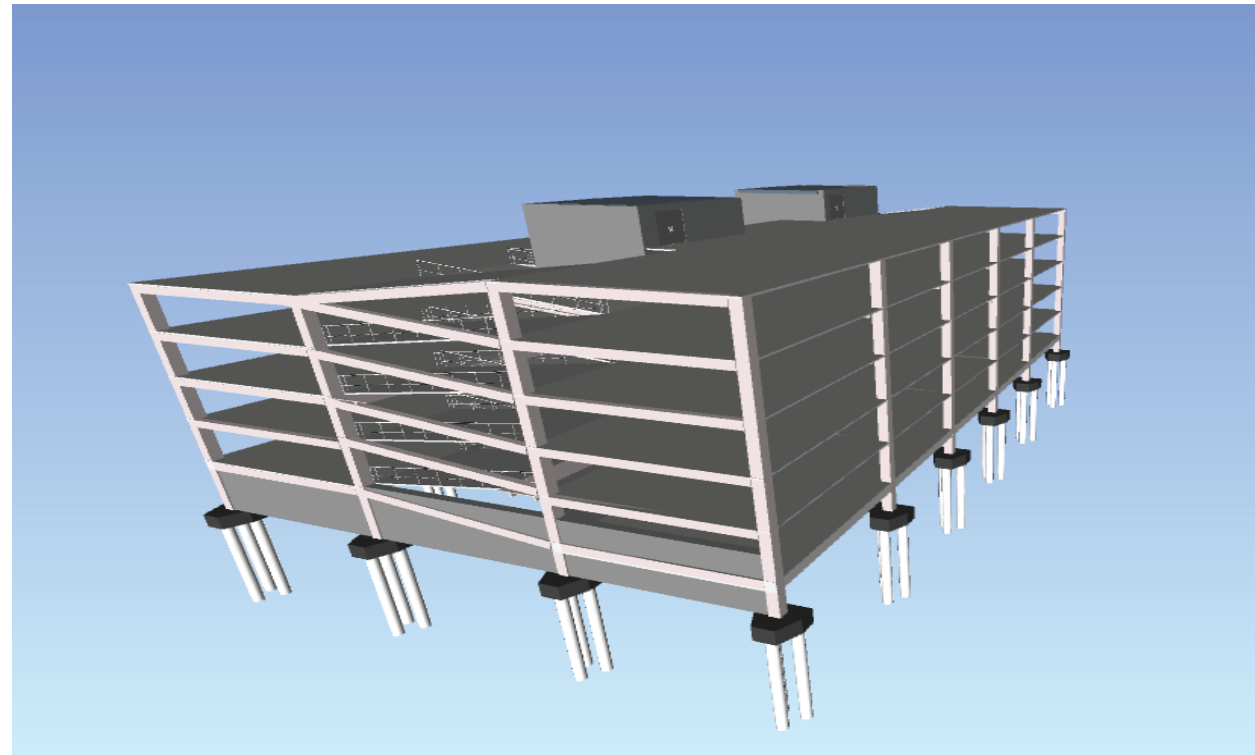

GARAGE PERFORATED SCREENS COMPLETION:

JUNE 1, 2023

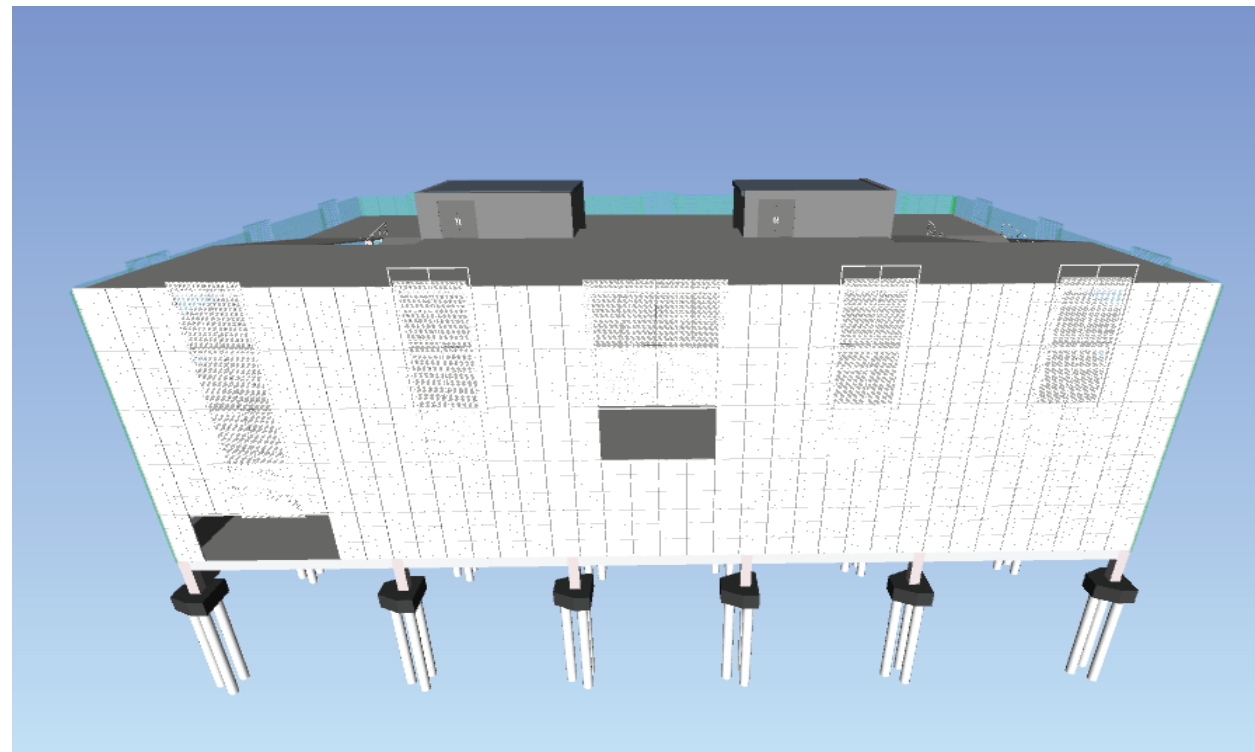

COLLABORATIVE
STUDIO 3B
GROUP 16

MEMBERS	INSTRUCTORS
CJ CHILDERS CONNER GRIFFIN LUKE MURRAY NOAH HEFLIN	ALEXIS GREGORY MOHSEN GARSHASBY BRIAR JONES HANS HERRMANN

PROJECT NUMBER
ASSIGNMENT 5.0

DATE
04/16/2021

DRAWN BY:
NOAH HEFLIN

DESIGN
DEVELOPMENT
5.0

C112

INTERSTITIAL SPACE CONCRETE WORK TO BEGIN:

APRIL 12, 2023

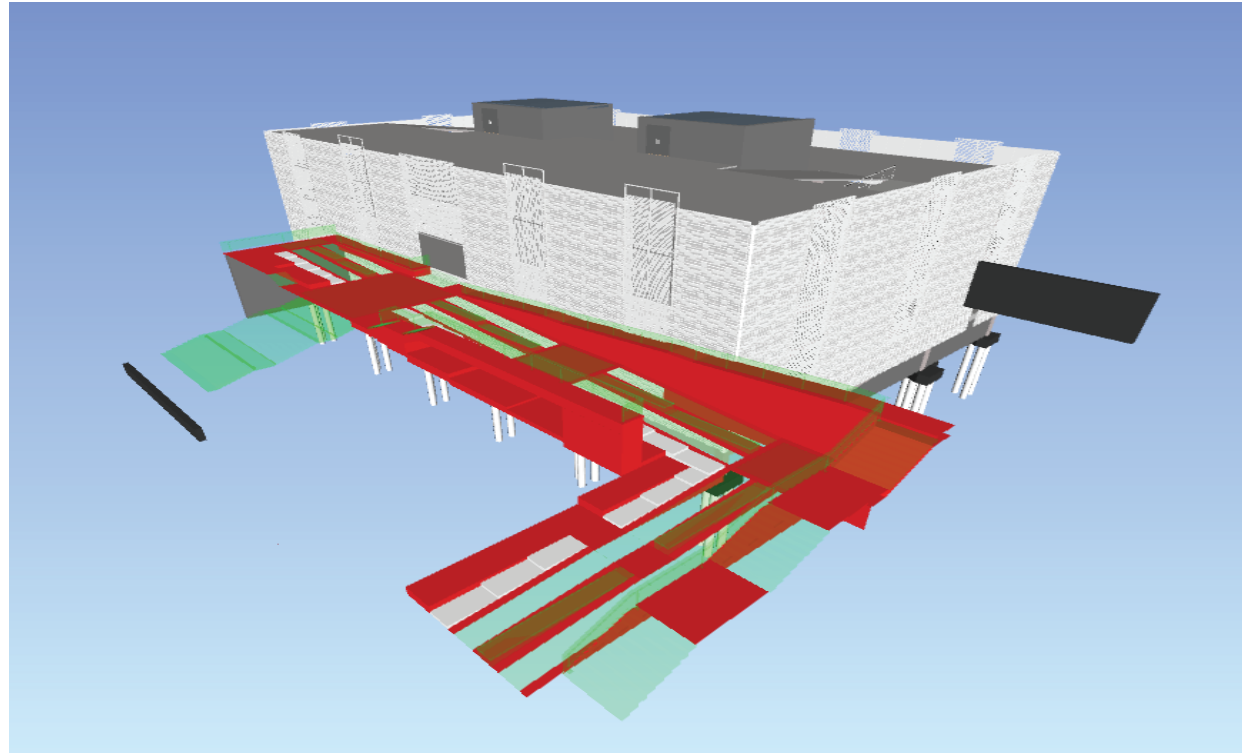

RETAIL SPACE BUILD-OUT BEGINS:

APRIL 24, 2023

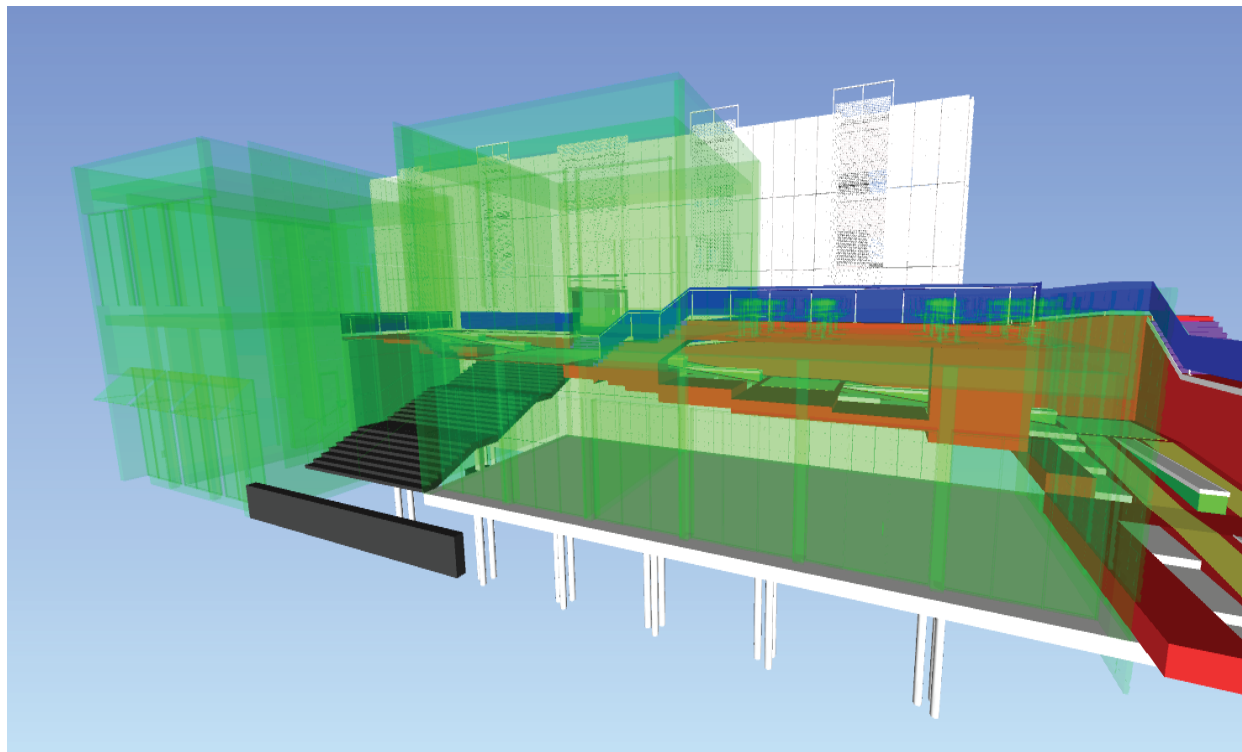

INTERSTITIAL SPACE BRICK WORK TO BEGIN:

MAY 24, 2023

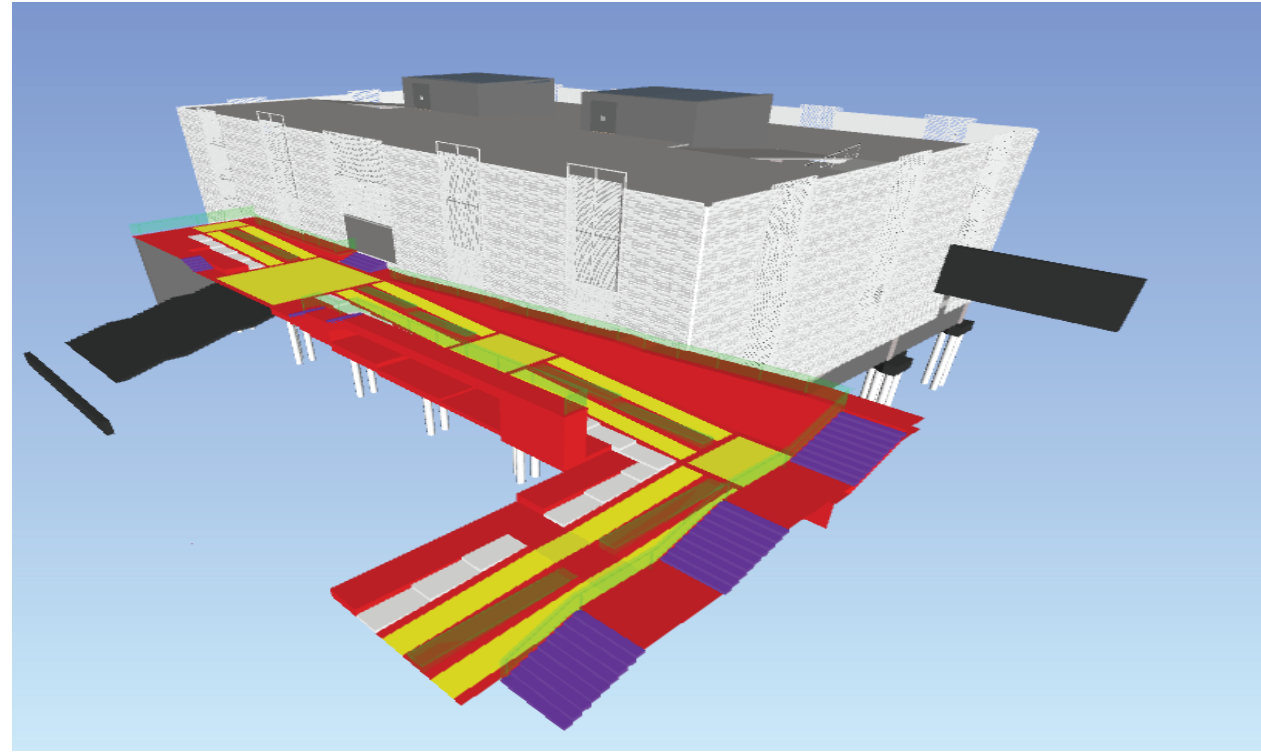

RETAIL EXTERIOR COMPLETION

AUGUST 25, 2023

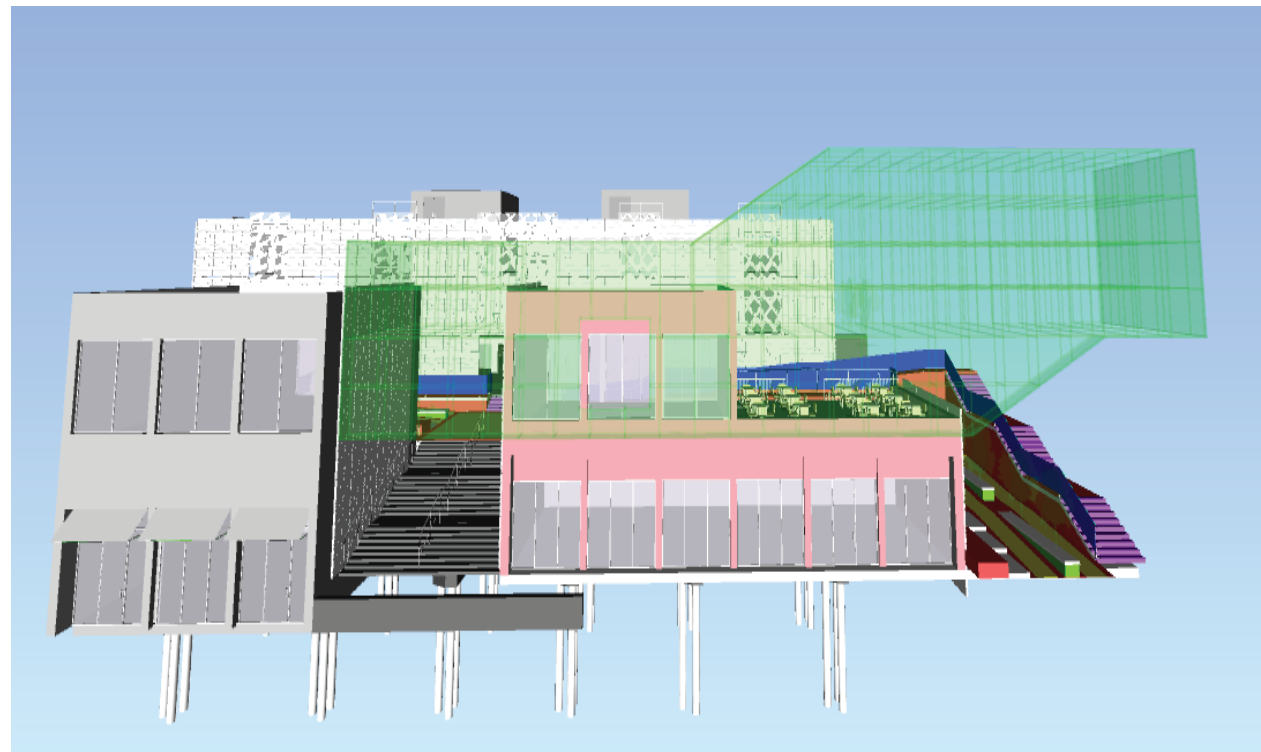

COLLABORATIVE
STUDIO 3B
GROUP 16

MEMBERS	INSTRUCTORS
CJ CHILDERS	ALEXIS GREGORY
CONNER GRIFFIN	MOHSEN GARSHASBY
LUKE MURRAY	BRIAR JONES
NOAH HEFLIN	HANS HERRMANN

PROJECT NUMBER
ASSIGNMENT 5.0

DATE
04/16/2021

DRAWN BY:
NOAH HEFLIN

DESIGN
DEVELOPMENT
5.0

C113

TRELLIS FRAMING: 16,005 L.F.

MATERIAL/LABOR COST: \$79,704

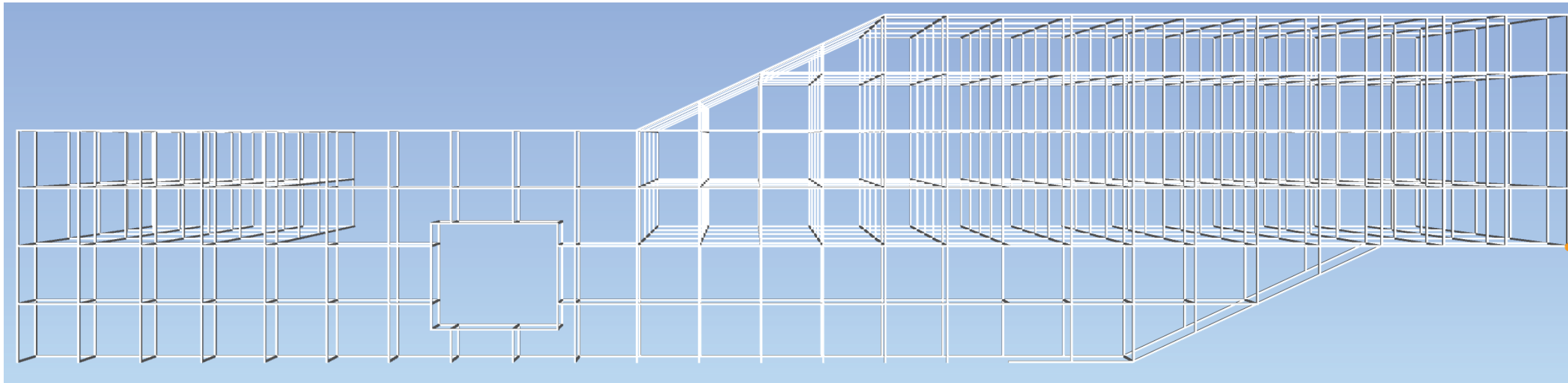

PERFORATED ALUMINUM SCREEN: 2500 SQ. FT

MATERIAL/LABOR COST: \$43,985

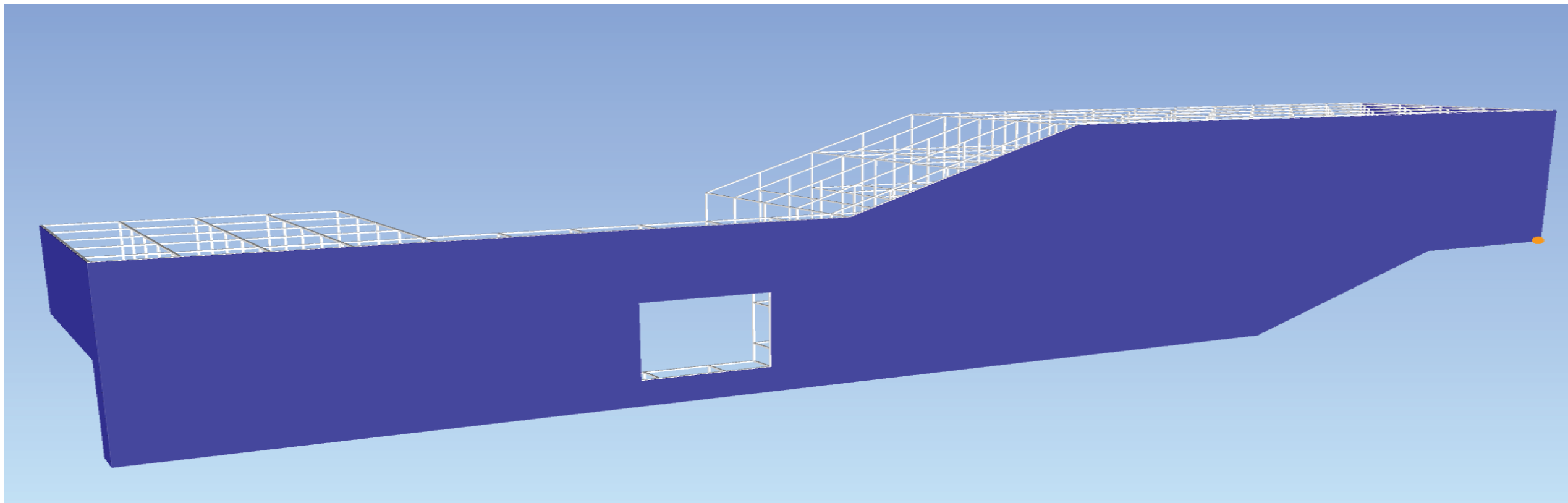

OVERALL COST TOTAL: \$123,689

COLLABORATIVE
STUDIO 3B
GROUP 16

MEMBERS	INSTRUCTORS
CJ CHILDERS	ALEXIS GREGORY
CONNER GRIFFIN	MOHSEN GARSHASBY
LUKE MURRAY	BRIAR JONES
NOAH HEFLIN	HANS HERRMANN

PROJECT NUMBER
ASSIGNMENT 5.0

DATE
04/16/2021

DRAWN BY:
NOAH HEFLIN

DESIGN
DEVELOPMENT
5.0

C114